

WESTBURY FIRE DEPARTMENT

PROBATIONARY DRILL

SPRINKLER & STANDPIPE OPERATIONS

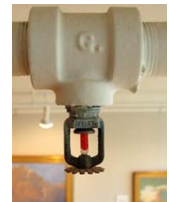
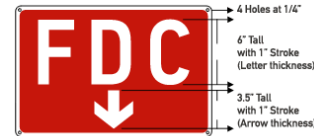

WESTBURY FIRE DEPARTMENT

PROBATIONARY DRILL

SPRINKLER & STANDPIPE OPERATIONS



Many new firefighter get confused between

Standpipe vs. Sprinklers

because the **FDC** (Fire Department Connection) on the outside of the building look the same.

Although they may have a similar purpose (getting water to a fire inside a building) their functions are completely different.



WESTBURY FIRE DEPARTMENT

PROBATIONARY DRILL

SPRINKLER & STANDPIPE OPERATIONS



STANDPIPE:

Is a pre-piped water supply system that allows Fire Dept hose to be connected from points inside the building.

Found in structures of large area (footprint), multiple floors or structures with both.

- Allows us to get **closer** to the fire, with our hose lines, **quicker** and prevents us from stretching large amounts of hose throughout the building before we can even close enough to begin firefighting operations.

What's happening to the fire when we have these Large stretches?

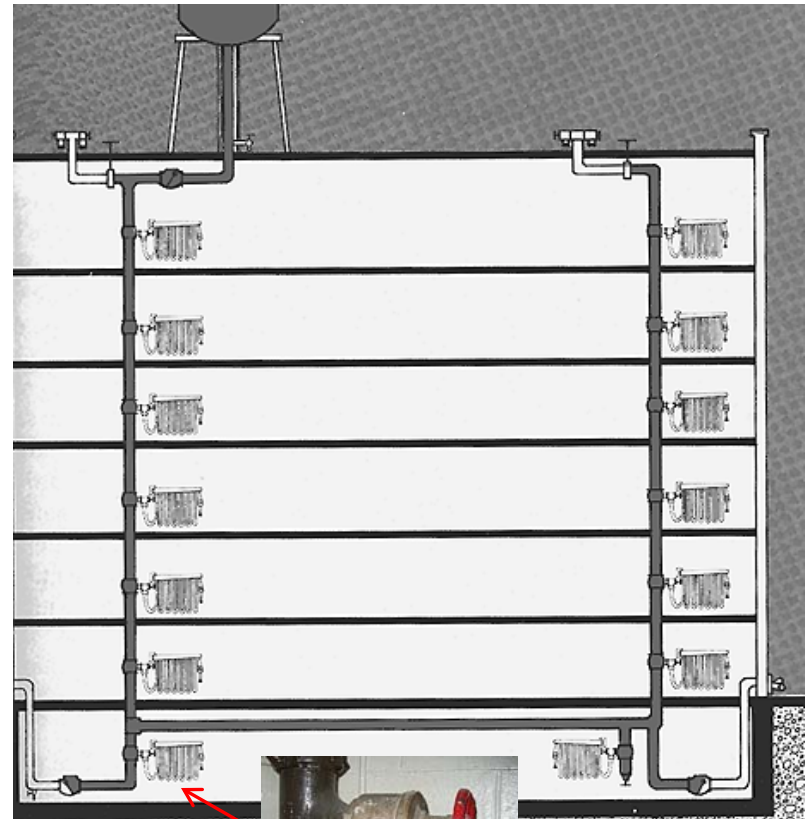

WESTBURY FIRE DEPARTMENT

PROBATIONARY DRILL

SPRINKLER & STANDPIPE OPERATIONS



SRINKLERS:

Is also a pre-piped water supply system but instead of feeding hose lines, they feed sprinkler heads throughout the building, as designed by an engineer.

- Typically found in high fire hazard structures or one with large occupancy. They are designed to keep fire confined to a specific area and not necessarily designed to extinguish the fire.

We are seeing more and more in residential applications, single or 2 family homes, to protection a truss building system or a heating system room.

Village of Westbury also requires residential sprinklers when a home's attic is sheet rocked, be aware these smaller residential sprinklers systems will differ from the commercial application, typically we will not be able to supplement the water source to them, most will be fed solely by local water.

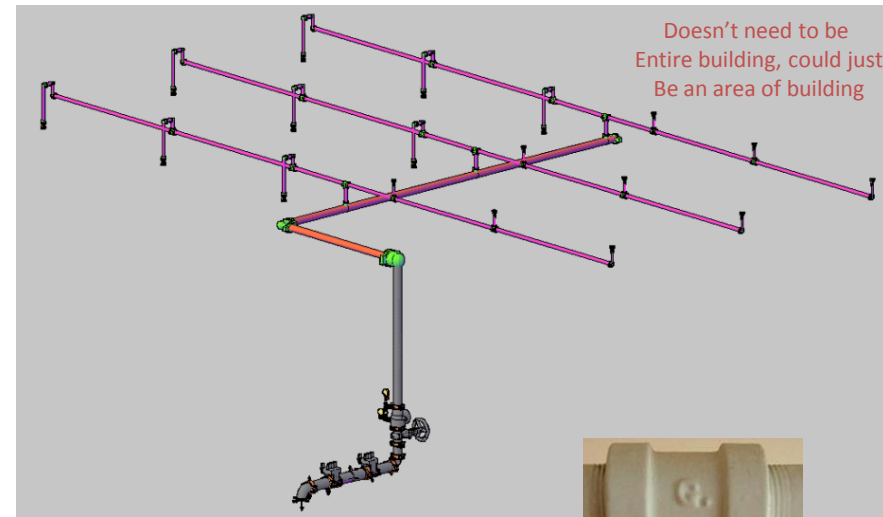

Doesn't need to be
Entire building, could just
Be an area of building



WESTBURY FIRE DEPARTMENT

PROBATIONARY DRILL

SPRINKLER & STANDPIPE OPERATIONS



Connecting our F.D. Hose to a FDC Sprinkler or Standpipe

The Engine will first need to gain a water source (hydrant) which will typically be in close proximity to the FDC.

-Does this mean that this hydrant will operational?

We need to be ready for anything!

- when the engine is at an operational hydrant (water source)
- we want to connect to the FDC using larges diameter hose possible , Typically our 5" hose.

Can we reverse lay, instead of Hydrant to FDC, can we go FDC to Hydrant?

The newer FDC, we are seeing are 5" Storz and not the standard 2.5" Siamese.

If this is the case, we can take our 5" Hose and make a direct connection to FDC.



5" Storz (sexless)



2.5" Siamese

WESTBURY FIRE DEPARTMENT

PROBATIONARY DRILL



SPRINKLER & STANDPIPE OPERATIONS

Connecting our F.D. Hose to a FDC Sprinkler or Standpipe

If we are confronted with a **Sprinkler** **and** a **Standpipe** FDC, next to each other, we always want to feed the **STANDPIPE** **first**, since this is what we'll be using.

Note:

The multiple Standpipe or Sprinkler FDC, found around a structure will all feed the entire, common, system.

Note:

Sprinklers and Standpipes are independent of each other, unless marked **Combo System**, only these will be feeding both sprinkler & Standpipe systems at the same time.

Example: Combo system – Source Mall



WESTBURY FIRE DEPARTMENT



PROBATIONARY DRILL

SPRINKLER & STANDPIPE OPERATIONS

Connecting 5" Fire Hose to a FDC
Sprinkler or Standpipe



WESTBURY FIRE DEPARTMENT

PROBATIONARY DRILL

SPRINKLER & STANDPIPE OPERATIONS



FDC – SIAMESE clapper Valve

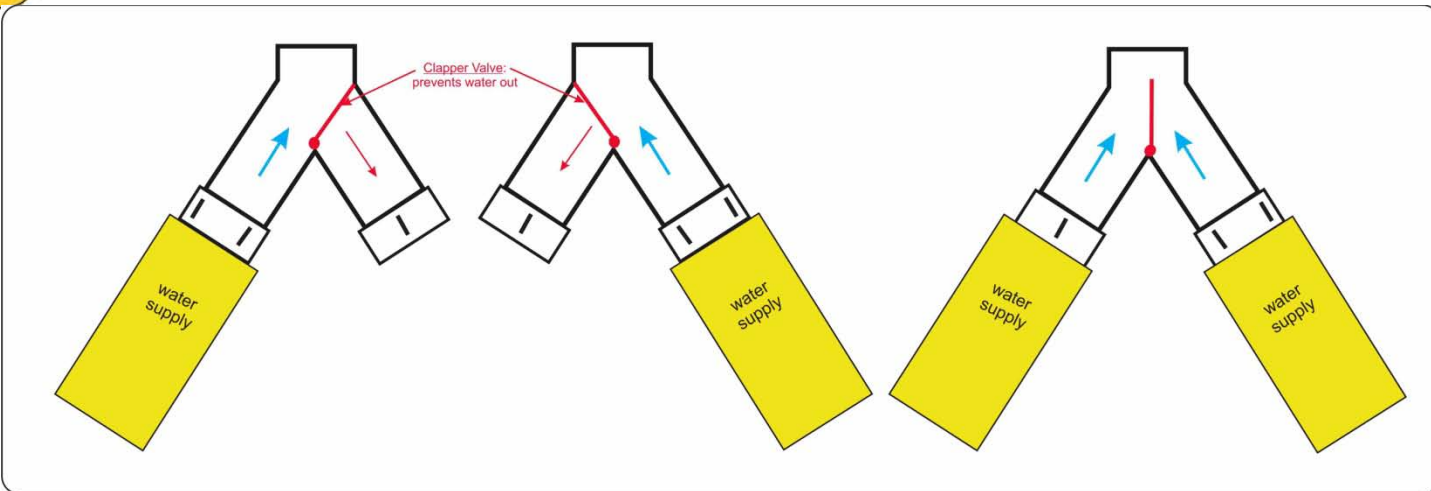

Note:

In a FDC Siamese, there is a clapper valve that directs the water flow. If only connecting 5” make sure the clapper is operational otherwise you’ll need to cap the side not being used. (gate it if nec.)

Note: if found with no caps – debris inside could hinder operations

WESTBURY FIRE DEPARTMENT

PROBATIONARY DRILL

SPRINKLER & STANDPIPE OPERATIONS



Connecting 2.5" Hose to a FDC Sprinkler or Standpipe

- When we decide to connect 2.5" hose to our FDC, get that **first** 2.5" connected as soon as possible, get operational before doing the second one.



WESTBURY FIRE DEPARTMENT

PROBATIONARY DRILL

SPRINKLER & STANDPIPE OPERATIONS



Overcoming obstacles at a FDC Siamese



Tap swivels to loosen paint, polish, dirt, etc.



Twist hose 4-5 turns, Insert, turn to the right



Insert siamese 3"x3"x3"
Insert hose

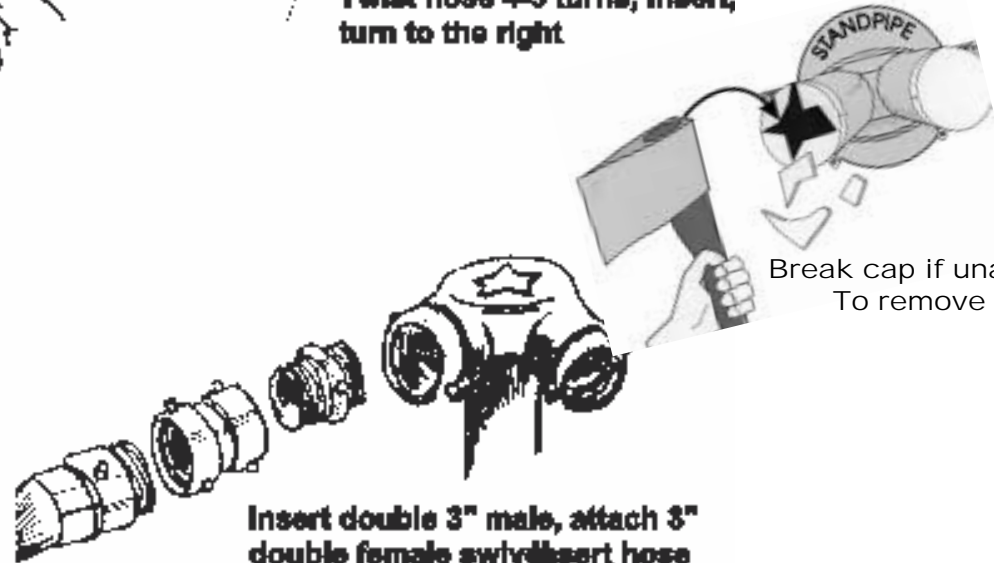

Break cap if unable
To remove

Insert double 3" male, attach 3"
double female swivel insert hose

WESTBURY FIRE DEPARTMENT

PROBATIONARY DRILL

SPRINKLER & STANDPIPE OPERATIONS



Incorrect

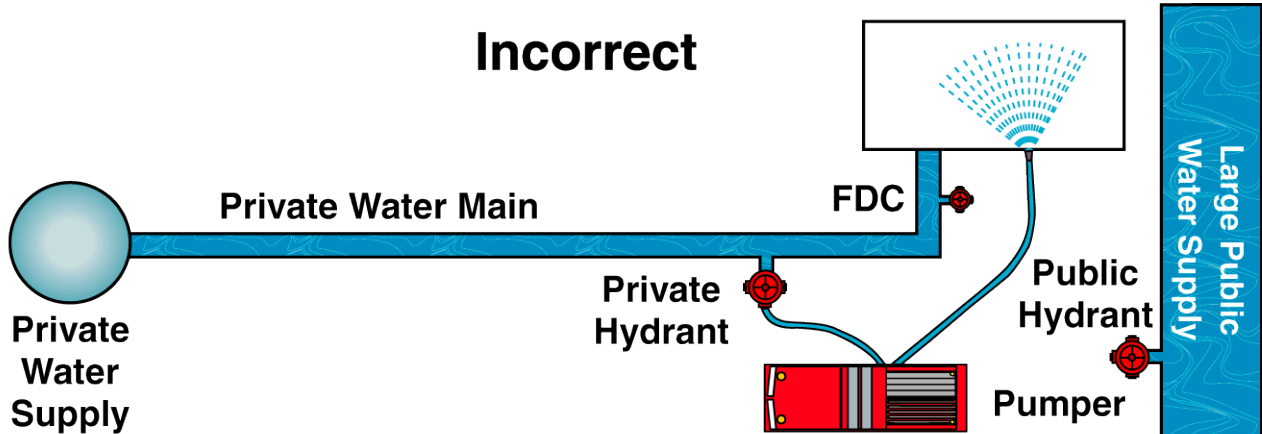

Correct

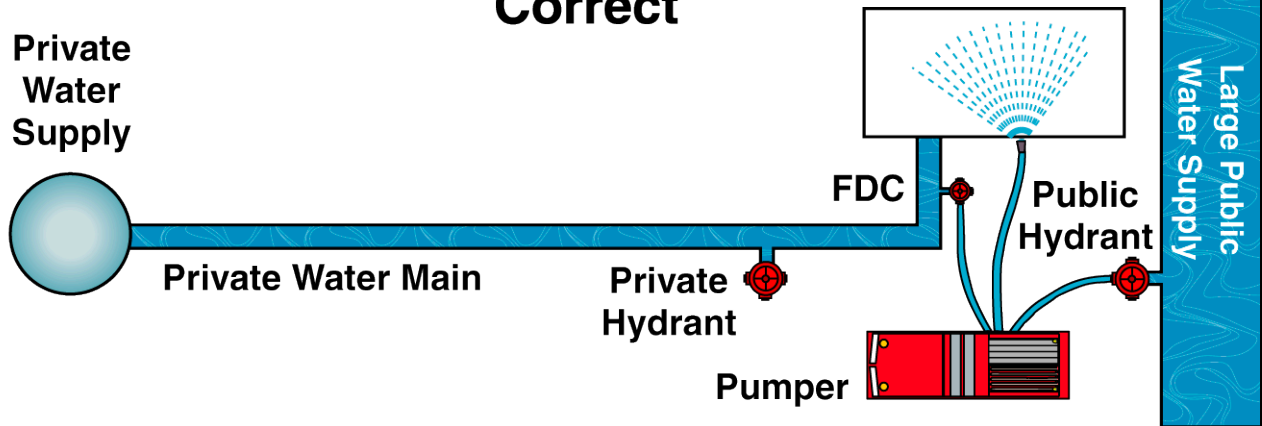

WESTBURY FIRE DEPARTMENT



PROBATIONARY DRILL

SPRINKLER & STANDPIPE OPERATIONS

Sprinkler Systems

Now that we have a FD water supply into the sprinkler System, is our job now done?

NO

It is very important for us to gain control of the buildings sprinkler system.

An active sprinkler, although it may be keeping the main body of fire in check, it is typically hindering our hose line advancement.

- the water being forced downward also forces down the products of combustion
- the smoke and heat are not lifting , even if the roof team cut us a nice big hole.

This will typically slow down us from advancing to the fire, visibility is harder, the TI camera doesn't hit on the hot room, because it's being cooled...



WESTBURY FIRE DEPARTMENT

PROBATIONARY DRILL

SPRINKLER & STANDPIPE OPERATIONS



Sprinkler Systems

Note:

A Sprinkler systems can be a **wet** or **dry** system.

Wet – the system is always charge with water or an extinguishing agent.

Dry – (typically found in outside or in unheated areas) example: garages...
These systems are charge with air – at a greater pressure then the water supply's pressure. When a head is tripped, the air escaping lowers the air pressure, making the water pressure greater and allowing the water to flow in pipe.



WESTBURY FIRE DEPARTMENT

PROBATIONARY DRILL

SPRINKLER & STANDPIPE OPERATIONS



Sprinkler Systems

When the head is actively flowing water,

This triggers a chain of events:

- Sensors in the pipe system will sense water movement and this activates an alarm , triggering a FD Response
- The moving water will activate the outside Sprinkler Alarm aka: “sprinkler gong or water flow gong ”
- The outside drain – will be flowing water out
The more water = the more water flow inside...
(could indicate more heads tripped then 1 ?)



WESTBURY FIRE DEPARTMENT

PROBATIONARY DRILL

SPRINKLER & STANDPIPE OPERATIONS



Active Fire Sprinkler Systems

Active Head
Flowing Water

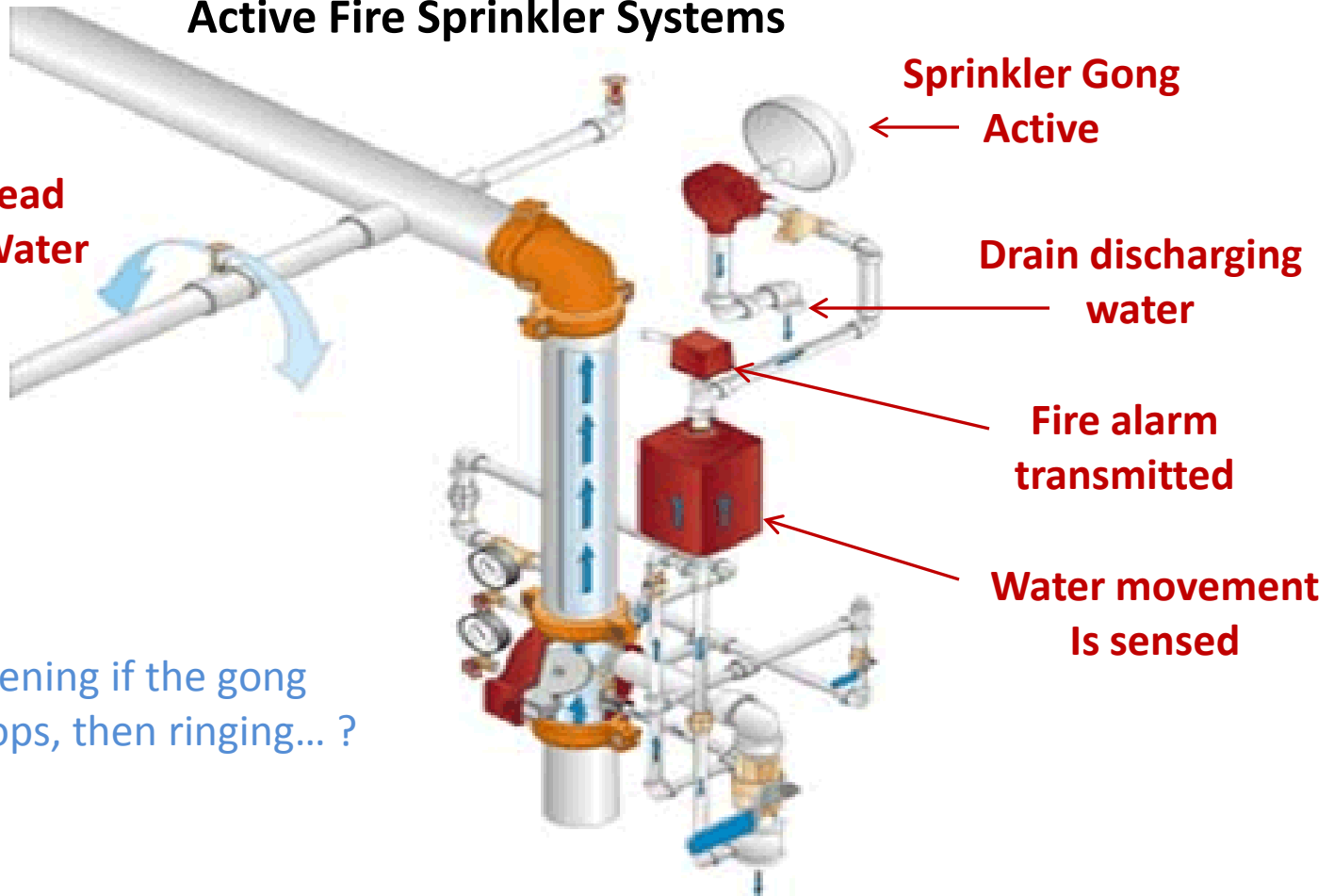

What is happening if the gong is ringing, stops, then ringing... ?

WESTBURY FIRE DEPARTMENT



PROBATIONARY DRILL

SPRINKLER & STANDPIPE OPERATIONS

Sprinkler Systems

What is important to us, as we arrive on scene is:
the gongs going off and water being discharged.

* Listen for gong & look for that trail of water in parking lot...



***These items** allow us to **isolate** the active riser, that we need to gain control of.

In buildings with multiple occupancy changes or the dividing of a once larger occupancy into many smaller ones, this may not be as **obvious** as you may think.

The gong closest to the fire building may not be the active one and the fire areas sprinklers could be getting fed from a different part of the building altogether.

These signs * and a good preplan will help you isolate the active riser for that fire area.

Note: *it's not uncommon to have multiple risers for 1 building, in different locations.*

WESTBURY FIRE DEPARTMENT

PROBATIONARY DRILL

SPRINKLER & STANDPIPE OPERATIONS



Sprinkler Systems

Once we've located the Active Riser, supplemented the water source with our engine, then we need to gain control of it.

Sprinkler controls valves can be found on the outside or inside of a building.

Typically in newer building:
They are found grouped in a "Sprinkler Room".



Closed Open
Outside Stem & Yolk (OS&Y)

WESTBURY FIRE DEPARTMENT

PROBATIONARY DRILL

SPRINKLER & STANDPIPE OPERATIONS



Sprinkler Systems

Typically in newer building:
Inside **"Sprinkler Room"**

Sprinkler alarm

Sprinkler Siamese

Sprinkler drain

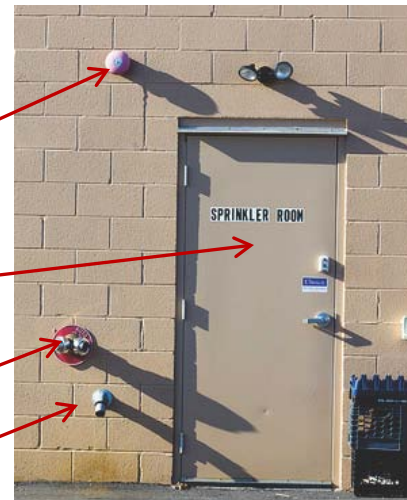

So when open door, what side will riser be on?

Older building – Attached to building:
Wall Post Indicator Valve

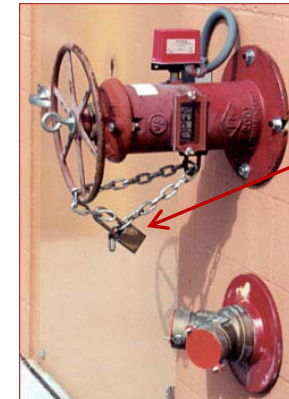

NOTE
Since Open Access
chain and locked
In open position

WESTBURY FIRE DEPARTMENT

PROBATIONARY DRILL

SPRINKLER & STANDPIPE OPERATIONS



Sprinkler Systems

When the FDC is **not attached to the building**: in front yard, out by the street, in a parking lot...

These risers could be in an underground pit near the FDC

or a **Post Indicator Valve** typically between FDC and Building



Due to our climate, This entire set up will be in a outside underground pit



Pit

WESTBURY FIRE DEPARTMENT

PROBATIONARY DRILL

SPRINKLER & STANDPIPE OPERATIONS



Sprinkler Systems

Gaining control of the sprinkler valves will typically require forcible entry, if the valves are confined in a room or in an outside underground pit.

For the Post indicators, or any sprinkler control valve with **common access**, you may not need to force entry to them, but the valve will be locked in the **open** position.

Once the hose line crew has made it to the fire area, they will request the sprinkler be shut down.

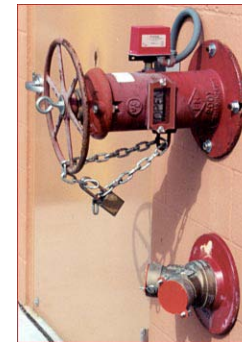

WESTBURY FIRE DEPARTMENT

PROBATIONARY DRILL

SPRINKLER & STANDPIPE OPERATIONS



Sprinkler Systems – Fire Pumps

Note: Sprinklers in large footprint buildings or especially taller buildings, the street water pressure may not be sufficient to supply enough pressure to the sprinkler systems – These building the sprinkler system's water will be supplemented by a **Fire Pump**, boosting the pressure.



← Diesel pump

Electric pump →



WESTBURY FIRE DEPARTMENT

PROBATIONARY DRILL

SPRINKLER & STANDPIPE OPERATIONS



Sprinkler Systems – Fire Pumps

These Fire Pumps need to be **shut down**:

1. When our Engine is connected to the sprinkler system and *we are now augmenting the water supply*
OR
2. When we have orders to shut down the sprinkler system, *if our engine is connected to the system or not.*

Provisions should always be in place to augment the system, plus restarting a pump is typically a simple few steps.

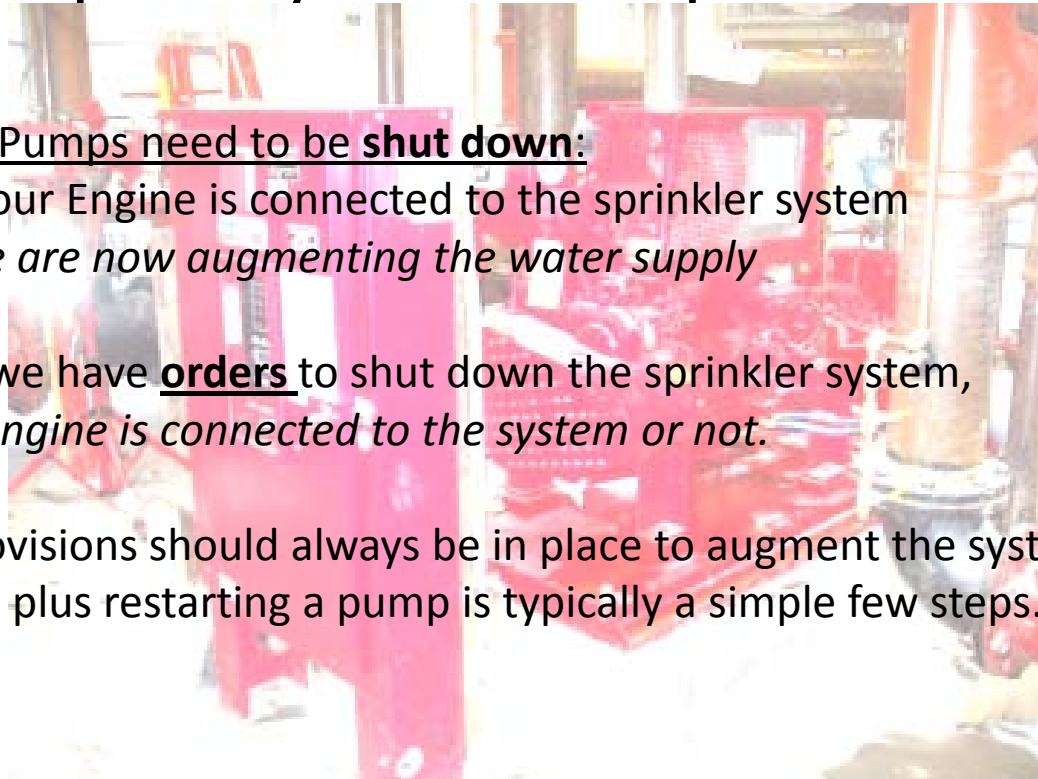

WESTBURY FIRE DEPARTMENT

PROBATIONARY DRILL

SPRINKLER & STANDPIPE OPERATIONS



Sprinkler Systems – Fire Pumps



Controller & Pump

Red Button – Stop

Green Button – Start

With Diesel may be turn key also

WESTBURY FIRE DEPARTMENT

PROBATIONARY DRILL

SPRINKLER & STANDPIPE OPERATIONS



Shutting Down Sprinkler Systems

All Locks... should remove and the valve ready to be operated, awaiting the orders to shut down the sprinklers

For the OS&Y valves you want to turn the wheel so the stem goes from **exposed** to inside the pipe:

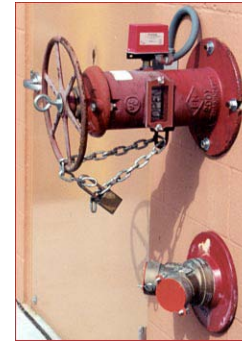

Exposed Stem
Open

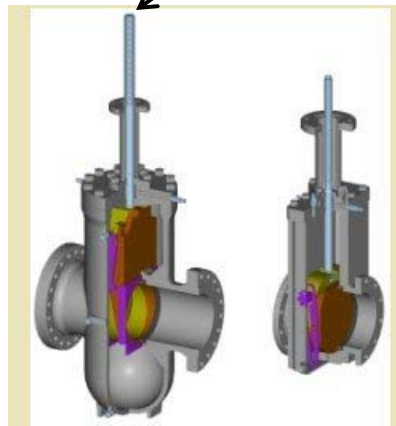

Hidden Stem
Closed



WESTBURY FIRE DEPARTMENT

PROBATIONARY DRILL

SPRINKLER & STANDPIPE OPERATIONS



Sprinkler Systems

For the Post Indicators – these work just like a Hydrant



Open
or
Closed

- Cut the lock freeing the crank handle
- Pull off handle
- Operate to nut as you would a Hydrant

- The indicator will let you know if **OPEN** or **CLOSED**

WESTBURY FIRE DEPARTMENT



PROBATIONARY DRILL

SPRINKLER & STANDPIPE OPERATIONS

Sprinkler Systems

Once the Sprinkler is shut down , is your job done?

NO, remain at the control valve.

- If the fire is unable to be controlled by line(s),
- if there is trouble with the lines...
- if there is a catastrophic event requiring regrouping

The sprinklers can always be reactivated.



WESTBURY FIRE DEPARTMENT

PROBATIONARY DRILL

SPRINKLER & STANDPIPE OPERATIONS



Standpipe System

Now that we have a FD water supply into the **Standpipe** System, what's next?

Does this mean we have water to the structure?

No

Once the MPO starts to flow water we'll get a better indication if our connection is effective. If they flows water and the rig is not continually flowing water, we're probably good.

But

If there is water flow, the rig is working hard and the hose team is not connected yet, we have to look for: broken pipe, open valve ...



WESTBURY FIRE DEPARTMENT

PROBATIONARY DRILL

SPRINKLER & STANDPIPE OPERATIONS



Standpipe System

Note:

Just like a Sprinklers Systems,
A Standpipe system can also be **Wet Or Dry**.

A **Wet System** will be supplied by town water,
and

A **Dry System**, *again typically in areas susceptible to freezing (parking garages)*,
will be dry, **until:** (1) a valve is opened putting town water into it or (2) we put the
water in with our engines.

In Both systems, we'll be connecting our hose to the system,

Wet – supplementing the water supply

Dry – we may be the only water supply and system is just a piping system.



WESTBURY FIRE DEPARTMENT

PROBATIONARY DRILL

SPRINKLER & STANDPIPE OPERATIONS



Standpipe System

If we are unable to make a connection to a specific FDC, Alternatives to get water to the standpipe system could be:

- find another FDC else where around the building
- the closest inside Standpipe Connection:
 - Remember** – will need a double female adaptor since you'll be trying to connect 2 male connections
- other inside connections could later be used to supplement the original connection, once man power allows, by feeding another lower, close standpipe connection.

Don't only think of an inside Standpipe Connections as a discharges, The system is a grid/loop... They can be fed from these points too!



WESTBURY FIRE DEPARTMENT

PROBATIONARY DRILL

SPRINKLER & STANDPIPE OPERATIONS

Standpipe System – of outside Siamese don't work:

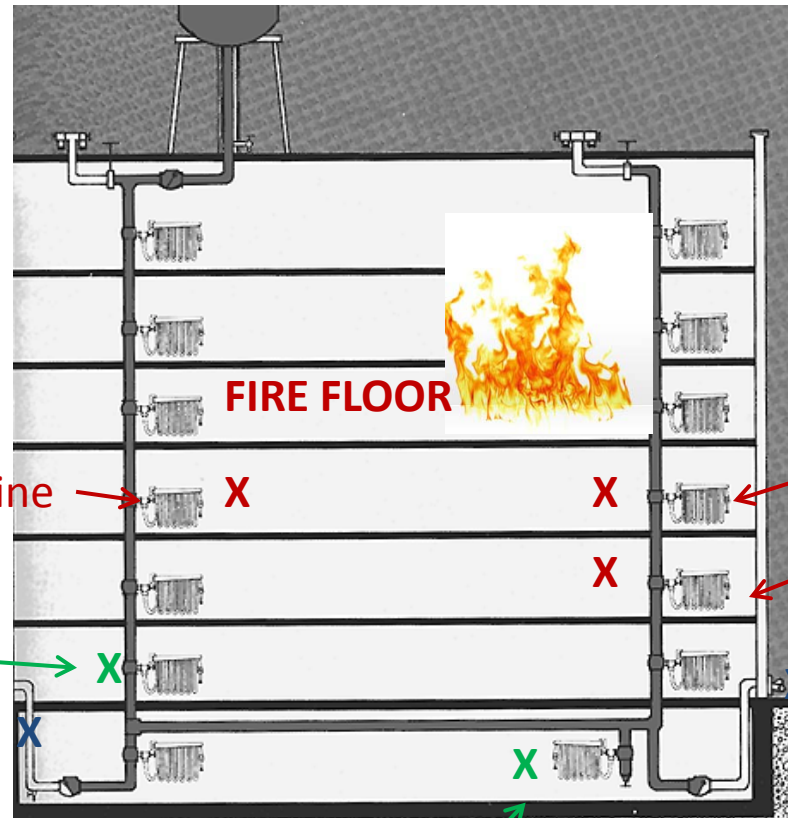

2nd Line → X

X ← 1st Line

X ← 3rdL Line

Connection Reversed
to a 1st feed – 1st Due
Connection Missing

X Connection Damaged

→ X
Connection Reversed to a 2nd feed – 2nd Due

WESTBURY FIRE DEPARTMENT

PROBATIONARY DRILL

SPRINKLER & STANDPIPE OPERATIONS



Attaching Attack Lines to Standpipe system

Standpipe Bag:



Pipe Wrench



Spanner Wrenches



Door Chocks



Thread Adaptor



Double Female Adaptor



Double Male Adaptor

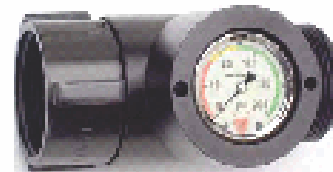

In-Line Pressure Gauge



45 Degree Elbow



Extra Nozzle



Hose Straps



Member with Standpipe Bag should have Radio & Hand light.

WESTBURY FIRE DEPARTMENT



PROBATIONARY DRILL

SPRINKLER & STANDPIPE OPERATIONS

Attaching Attack Lines to Standpipe system

Hose Team's – Equipment

Nozzle : 2 High Rise Packs (make sure there is a Nozzle's in bag or bring one)

Officer : Officers tool - 1 High Rise Pack, Hand light & Radio

Back Up: 2 High Rise Pack

Control : Standpipe Bag – 1 High Rise Pack, Hand Light & Radio

Rule of thumb:

1st Line – Connecting - Floor below Fire Floor

2nd Line – Connecting - 2 Floors below Fire ...

WESTBURY FIRE DEPARTMENT

PROBATIONARY DRILL



SPRINKLER & STANDPIPE OPERATIONS

Attaching Attack Lines to Standpipe system

GETTING WATER FROM THE SYSTEM

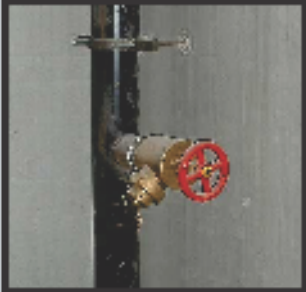

Standard Type Connection



Cabinet Type Connection



Standpipe Connection

(if needed)
Adaptor
Pipe Thread - to -
Our Hose Thread...

In-Line Pressure Gauge

(if connecting to a cabinet type)
45 degree elbow

High-Rise Packs
@ 50 lengths
300 max.
then the appropriate nozzle



Pressure Regulating Device

PRD's need to be **REMOVED** before making FD Connection



Restricts Water flow, as it is turned closed

WESTBURY FIRE DEPARTMENT



PROBATIONARY DRILL

SPRINKLER & STANDPIPE OPERATIONS

Attaching Attack Lines to Standpipe system

Hose Team – Equipment

Control : will be making the connection to the stand pipe

Nozzle and Back up: Set up hose for easy advancement to fire

Officer – should be accessing floor plan, of the set up floor, to gain layout and determine best means to attack.
(typically in high rise – floor layout same floor to floor)

How many doors down is “504”, will be same a “404” - on right or left?

Maybe easier to advance the floor below hallway then go up, then to go up to fire floor and advance to fire apartment?

WESTBURY FIRE DEPARTMENT

PROBATIONARY DRILL



SPRINKLER & STANDPIPE OPERATIONS

Attaching Attack Lines to Standpipe system

High Rise Pack:

References - Diagrams are NOT to scale

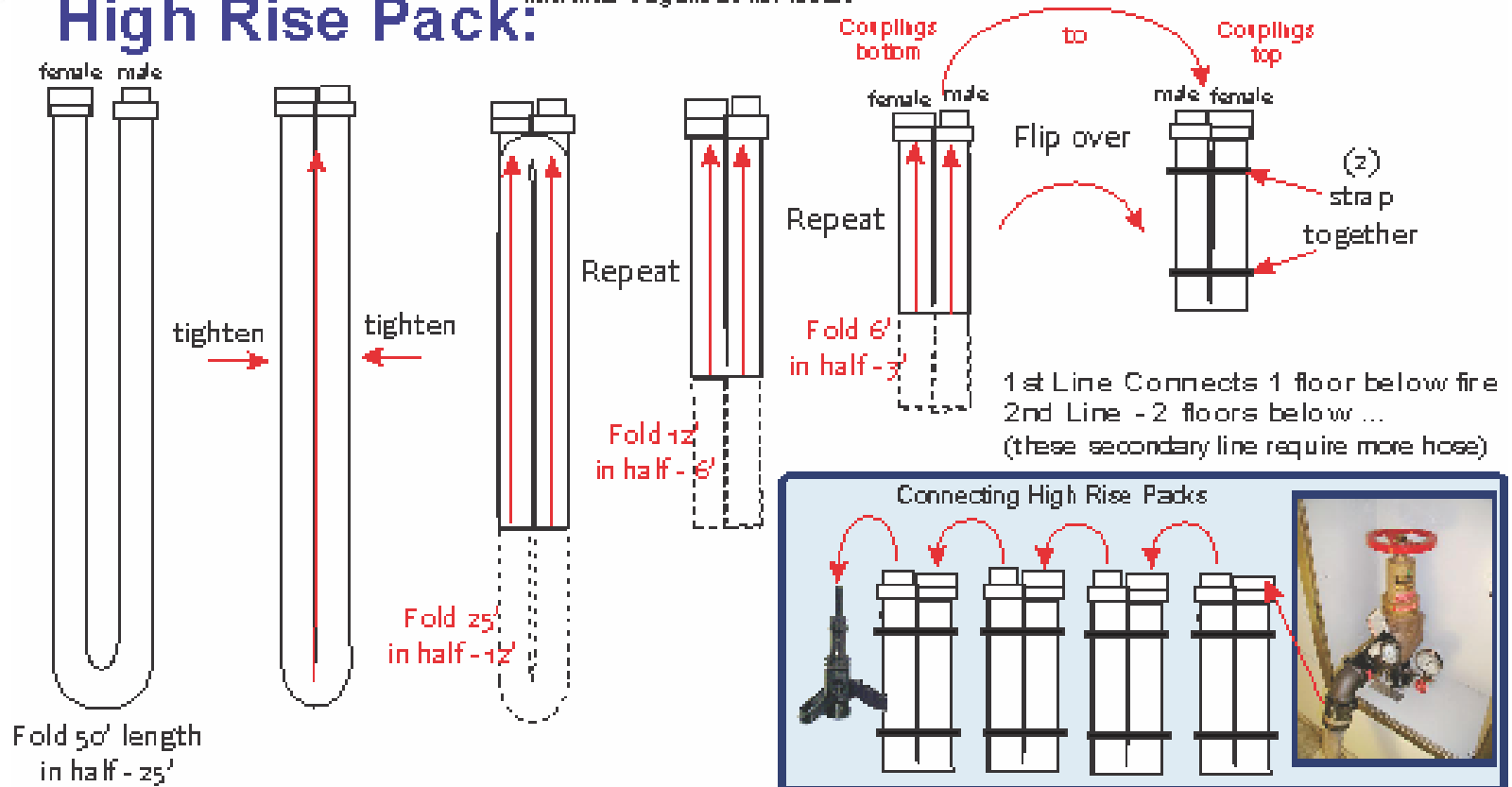

WESTBURY FIRE DEPARTMENT



PROBATIONARY DRILL

SPRINKLER & STANDPIPE OPERATIONS

Attaching Attack Lines to Standpipe system



As a safety for civilians, there may be a pin that needs to be pulled before the pressure can be adjusted.

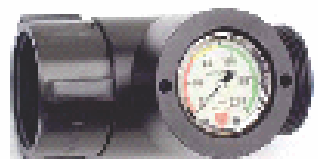

In Line Pressure Gauge
Pressure Readings

150' 2.5" Hose - Solid Nozzle
70 PSI flowing water

Add 10 psi for every length of 50' hose added (300' Max) and

5 psi for every floor stretched above the original (2nd line - 2 floors below)



WESTBURY FIRE DEPARTMENT

PROBATIONARY DRILL

SPRINKLER & STANDPIPE OPERATIONS

Attaching Attack Lines to Standpipe system



When advancing hose line, use gravity to your advantage.

Whenever possible, try to get the hose in an easily advancing position before orders are given to “control “ to charge the line.

Length of hose being used by 1st line should be relayed to 2nd line, They should always have **more**: (1) starting from further away, (2) if 1st line does come up short – 2nd line can advance past 1st line and make the fire.

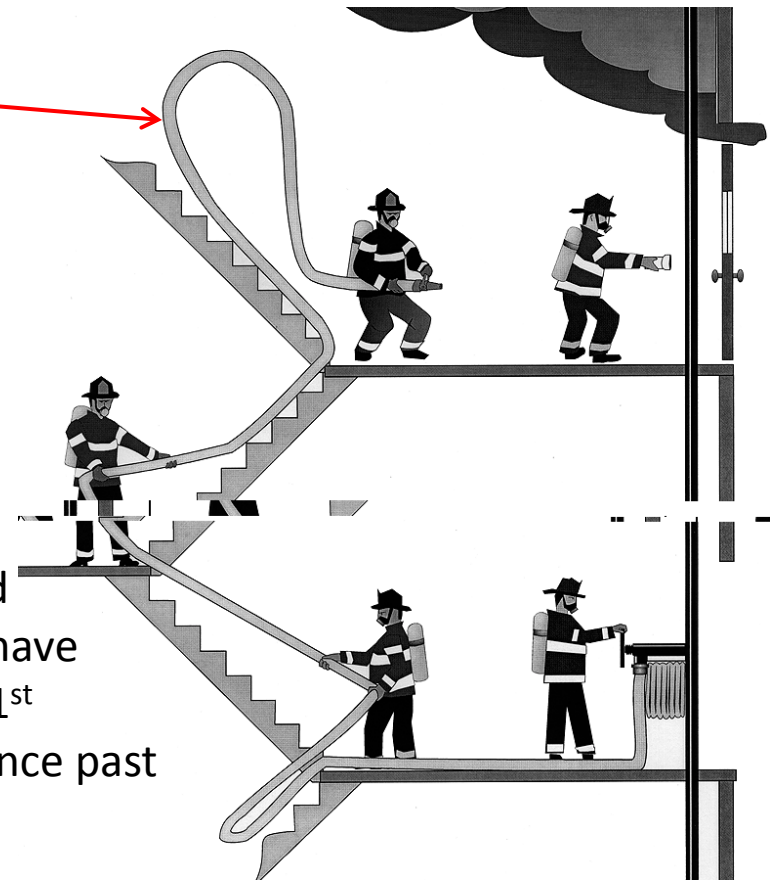

WESTBURY FIRE DEPARTMENT



PROBATIONARY DRILL

SPRINKLER & STANDPIPE OPERATIONS

Sprinkler & Standpipe Hands on portion

End of Lecture

Part 2 of Drill :

Gear up – going to Source Mall to Review:

- Connecting to Sprinkler System – using (2) 2.5” hose
 - Gaining access – sprinkler room and OS&Y’s
 - Controlling Fire Pump
 - Shutting down Sprinkler System
 - Getting System back operational

WESTBURY FIRE DEPARTMENT



PROBATIONARY DRILL

SPRINKLER & STANDPIPE OPERATIONS

Sprinkler & Standpipe Hands on portion

Part 3 of Drill :

Gear up – going to Roosevelt Field Mall to Review:

- Connecting to Standpipe System – using 5” hose
- Connecting to stand pipe if Siamese not operational
 - Review Standpipe bags
 - Connecting our hose to system
 - Getting High Rise packs into operation
- Setting pressure using in line pressure gauge
 - Hose line positioning & advancement
 - Repacking High Rise packs